

Z-D-OUT

5 RELAY OUTPUTS MODULE / RS485

Used to pilot 5 output SPST relays from all of the control systems which are able to communicate with the transmission protocol MODBUS RTU through the RS485 serial interface.

The instrument comprises 5 SPST NO output relays with negative in common and 5 A 250Vac capacity resistive loading, 2 A inductive loading.

For each output it is possible to set whether the state of relays if at rest, if so, it should be NO otherwise NC as well as the state to which the relays need to be taken upon start-up or in the case of lack of communication, including a delay which can vary between 50 and 2500 ms.

The wiring of the power supply and serial bus is facilitated by the use of a support bus that can be lodged within the DIN guide. Such a system also allows for hot swapping, that is, the insertion and extraction of the module from the bus without the interruption of the communication nor the power supply to the remaining part of the system.

Frontal signalling LEDs for: presence of power supply, anomaly, state of the 5 inputs, reception/transmission of data.

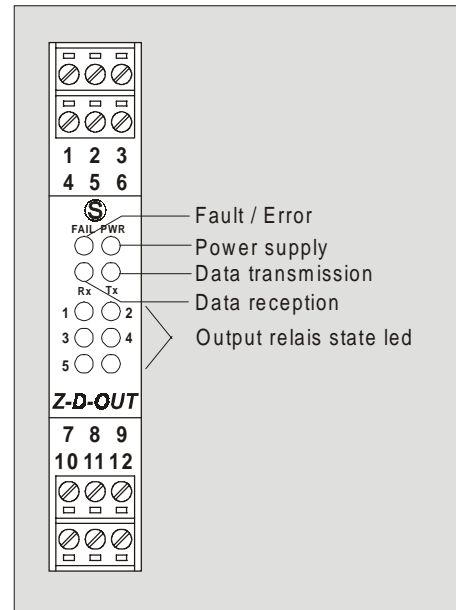

TECHNICAL DATA

- Power supply : 19 - 40 Vcc / 19 - 28 Vca - 50/60 Hz, power consumption max. 2,5W
- Input galvanised separation / the remaining circuits are at low voltage : 2500 Vac
- Interface : serial RS485 2 wire with settable velocity : 4800, 9600, 19200, 38400, 57600 baud
- Communication protocol : MODBUS RTU
- Communication time : < 10 ms (@ 38400 baud)
- Connection distance : up to 1200 m
- Outputs : 5 relay type SPST NO with common
- Current capacity : resistive load 5A 250Vac , inductive load 2A
- Maximum total current : 12 A on common clamp (see connections)
- *For further information make reference to page 2.*

POWER SUPPLY

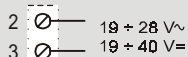

Power voltage must be in a range from 19 to 40 Vdc (indifferent polarity), from 19 to 28 Vac. **Upper limits must be exceeded, if it happen there could be damage for module.** It is necessary to protect power source from possible module's failure by fuse correctly dimensioned.

OUTPUTS

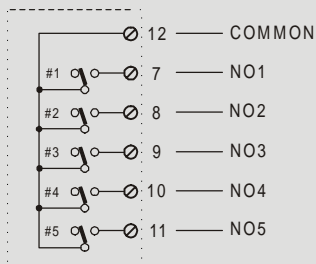

SERIAL INTERFACE

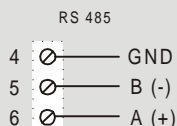

BUS SUPPORT DIN TYPE

The connection, for serial interface and feed of the module, is also situated on the connector on the instrument bottom.

This connector allows the connectin by bus through the support that must be installed in the DIN guide.

PROGRAMMING

All of the settings of the module, such as the type of input, setting of the digital filters, velocity of the serial interface, address of the module, etc. can be configured by means of the appropriate Z-PROG software.

EXAMPLES

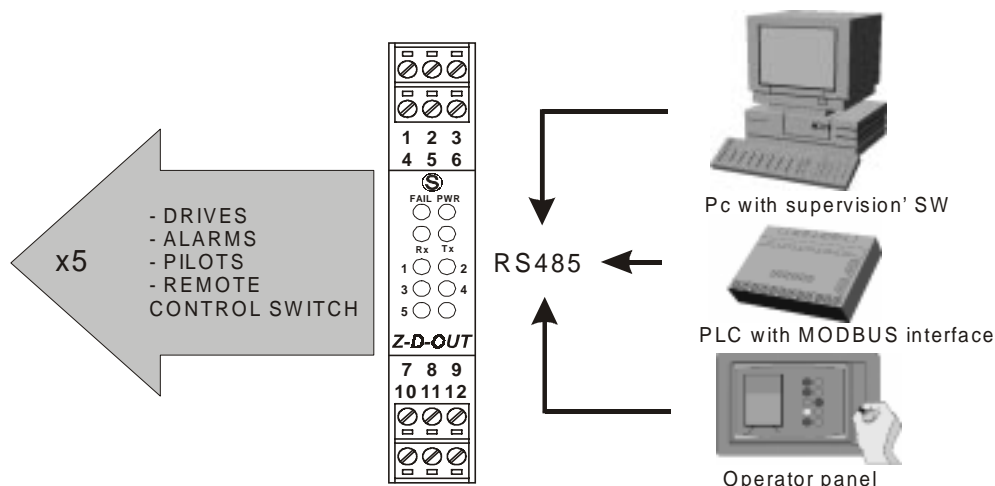

Via Germania, 34 - 35127 PADOVA - ITALY
 Tel. +39 049 8705355 - 8705359 - 8705408
 Fax +39 049 8706287
 e-mail: info@seneca.it
 Internet: www.seneca.it

ISO 9001

